

BASIC DESIGN THEORIES FOR THEATRICAL LIGHTING AND IT'S APPLICATION

**VERSION 5
April 2000**



**Written By:
Dean A. Sternke**

Prepared By:

MIS

Mainstage Theatrical Supply, Inc.
Products for the Entertainment Industry

www.mainstage.com

This pamphlet contains basic information on lighting theory and the equipment necessary to fulfill this theory for the design of theatrical style lighting in multi-purpose facilities including: theaters, churches, and other performance spaces. This updated brochure includes the article "Lighting noise in your Sanctuary".



Published by:

**Mainstage Theatrical Supply, Inc. - MTS North
129 W. Pittsburgh Avenue
Milwaukee, WI 53204
(414) 278-0878 or (800) 236-0878
email: MTS-North@mainstage.com**

**Mainstage Theatrical Supply, Inc. - MTS South
2515 W. Cervantes Street
Pensacola, FL 32505
(850) 434-2080 or (800) 851-3618
email: MTS-South@mainstage.com**

This brochure is offered free of charge in printed form. It is also available in .pdf format from the Mainstage website, www.mainstage.com, or the Mainstage Resource CD-Rom.

DESIGN CONSIDERATIONS

The method for selecting equipment is best started by completing a lighting design. Equipment can then be selected to fulfill this design. To design the lighting, several physical aspects of the equipment must be known along with the basic theories of stage lighting.

GENERAL LIGHTING THEORY

Indoor theatrical lighting is designed in a manner to emulate the natural highlights and shadows that are created by the sun, or similarly, the reflection of the sun by the moon. Without these shadows and highlights, the human eye will sense an incongruity, attempt to correct it in the mind and eventually tire and lose interest in viewing the object. Once this occurs the eye will move on to other objects to be refreshed, eventually this will allow audio contact to be broken as well. Proper highlights and shadows, at proper light levels, maintains longer eye and audio contact keeping the audiences attention focused on the event. This is important for plays, church services and even speakers from a podium.

Below are several of the main components to implement this theory.

The Sun: The sun strikes the northern hemisphere at a relative 45 degree angle; this angle produces specific highlights and shadows that are considered normal through the constant viewing of this arrangement. The extreme intensity of the sun creates a strong highlight on one side of a three-dimensional surface and strong shadows on the remaining areas. In a theatrical design, this would be the "key" light. Since the sun is so intense, it also generates a great deal of reflected (or bounce) light off of the surrounding surfaces. This reflected light fills in the shadows on the remaining sides of the object; in a theatrical design, it would be called the "fill" light. The intensity of this fill light is less than the intensity of the key light. The sun produces a white light that, when reflected off a surface, picks up the coloration of that surface. This bounce light fills the shadows with this colored light. This becomes the basic justification of the colored lighting in Theatre. It would be easy to simulate the sun and shadows indoors if we had a lighting fixture that could produce the same intensity as the sun. Unfortunately, this fixture is not available and we must use multiple fixtures to simulate the same effect.

The Moon: The moon provides a similar source and angle of light, but there are some significant differences, as we know, between sunlight and moonlight. Because moonlight is reflected sunlight, it is less intense and does not create the same bounce or fill effect. Nighttime lighting has much more contrast, or shadows, than daytime lighting.

THEATRICAL LIGHTING THEORY – STRAIGHT ON VIEWING

To duplicate the sun's highlight and associated bounce light indoors, we must provide three lighting instruments as a minimum: one fixture to create the highlight (the key light) and two to create the associated fill light. The three fixtures can adequately illuminate a three-dimensional object on all sides. Though positions can vary, a basic design would include one fixture placed at a 45-degree angle above and 45 degrees to one side. This would be the key light. The second fixture at the same 45-degree angle above and to the side. A third light would be placed directly above or at a sharp angle to the rear, and this would also be a fill light

(depending on its position, this is also known as a “downlight” or “backlight”). These three fixtures produce illumination that will be perceived to be similar to that of natural sunlight. The 45-degree angle is not unchangeable but keep in mind that extreme angles create extreme effects. A flat angle will create a generally shadowless light on the object, which is hard to control and tends to flatten the features of a person or object and creates a generally uninteresting kind of light. Conversely, an extremely sharp low angle of light from above or below will create exaggerated shadows on the face, which the eye is not accustomed to seeing. For example, a monster effect can be created by lighting a face from below, causing reversed shadows and an unnatural look.

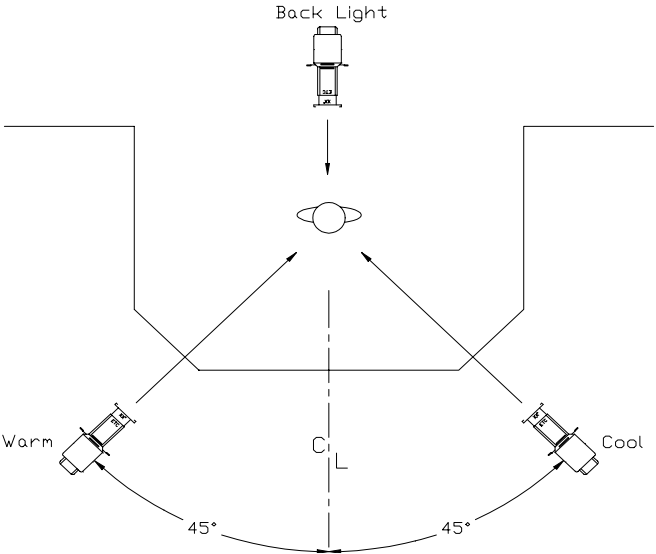

Figure 1

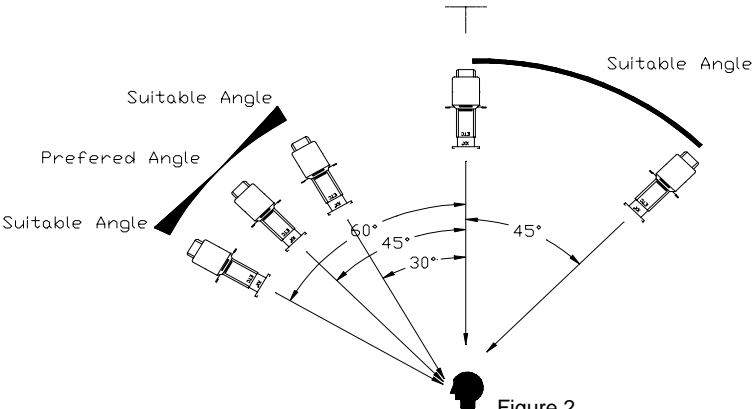

Figure 2

The lighting for a night scene uses the same set up and the same fixtures. The moon creates a similar angle of light; however, the lighting should be less intense.

To provide more options and colors to your lighting setup, more fixtures are hung using the same principle. First try adding additional back or down lights to increase the fill from the back, then add fronts for more key and fill possibilities.

THEATRICAL LIGHTING THEORY – MULTIPLE VIEWING ANGLES

The above theory is a basic design for one direction of viewing. If there is seating on three sides of a platform, the theory remains the same but the minimum layout changes. Using only two fixtures from the front would provide the viewer sitting on the side either all key light or all fill light, thus defeating the modeling effect you are trying to create. It is necessary to maintain the key and fill relationship for all viewing angles to create the shadows and highlights needed to model the object. A four-light front lighting scheme (See Figure 3) with two “keys” and two “fills,” provides this necessary relationship for ¾ round seating. The fill lights from the back remain the same.

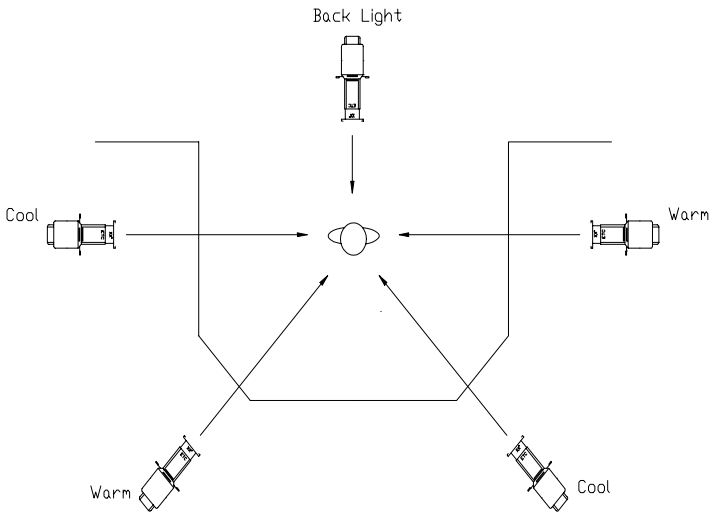

Figure 3

One cost-effective option to the four-light system is the three-light system (See Figure 4). Similar in theory to using four lights, three lights are positioned so that each viewing angle sees a key and a fill light. Two key lights from the sides and a fill light from the front will allow the fill light to perform double duty and provide each viewing angle with a key. Additional viewing angles would require additional fixtures using the same method.

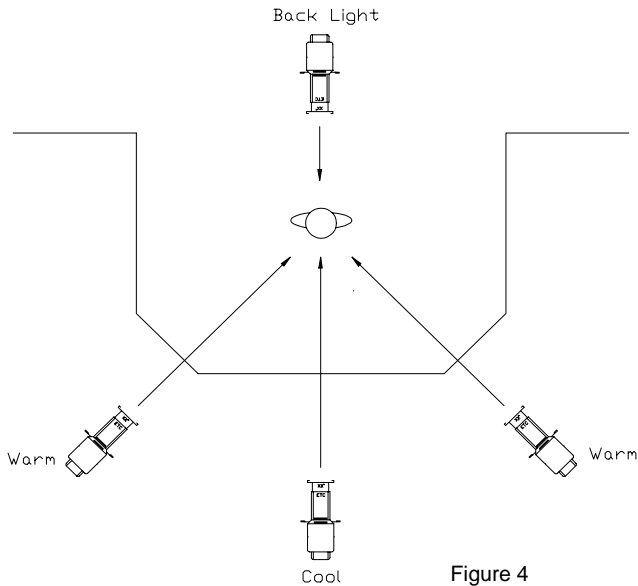

Figure 4

THEATRICAL LIGHTING THEORY – EXPANDED

Other positions can be used to enhance lighting effects while still maintaining the theory-dictated parameters. Since bounce light radiates 360 degrees from the source, fixtures that act as fill lights can be hung in any position. In addition, the sun does not rise or set at a relative 45-degree angle. Extreme angles change the direction of the fill light. Fixtures hung from a side angle can be used to emulate the sun's rising or setting. This side angle provides additional modeling of an object or body. It is heavily used in dance lighting to provide the audience with the best possible view in order to define the shape of the body.

COLOR THEORY

Once the angles are chosen for illumination, color selection should be the next design element concentrated on. Humans, either from nature or artificial lighting, have been conditioned to associate certain colors of light with certain times of the day. Most people think of a middle-blue to dark-blue color as night because the eye has difficulty in discerning color in low levels of light. Also, the sun is considered yellow or light amber, though it is really white light. Red is associated with fire, although fire can include the full spectrum of light. These ingrained color responses allow the theatrical designer to properly light indoors and simulate outdoor lighting moods. Theatre fixtures are manufactured with a holder that accepts thin sheets of plastic color media called gel. Although gels are available in hundreds of shades, the selection of colors is very difficult to write about or teach. Fortunately, the sheets of gel are relatively inexpensive and trial and error can be the best method for finding the best color for your purposes. If your lighting instruments are attached to dimmers, you can change the colors of a single gel simply by increasing or decreasing the intensity of the lamp. The light from a lavender gel will become increasingly red as its lamp intensity is reduced. A limited selection of fixtures and colors does not necessarily mean a limited color

palette. With practice you can learn how colors react to different intensities and how they react when used together.

The selection of the basic key and fill colors again should emulate the sun or moon. The key color should be warm like sunlight and the fill should symbolize a reflection from the earth's surfaces which are typically cool (gray concrete, brown wood, green leaves, etc). A good rule of thumb for basic lighting set ups is to choose a warm color and a cool color with similar color intensities. A brilliant yellow light would seldom produce a dark blue reflection; however, a deep lavender key could produce one. When using multiple key and fill angles it is possible to select gel colors which act as both a warm and cool light. For example when using three angles of front light, a rose tint could be used from the right, light lavender in the ones from the center and a medium blue in the ones from the left. The lavender would look cool when used with the rose yet warm when used with blue. Potentially, the medium blue run at full intensity could become the warm against a very low-intensity lavender. During a production with many scenes the entire color look of the light could be altered from scene to scene while still maintaining the basic lighting theory.



Gel colors must also be selected with scenery and costumes in mind. White light is a combination of the primary (red, blue and green) and secondary (magenta, cyan and yellow) colors of light. These colors (wavelengths) are necessary for viewing pigment colors. Pigment is what provides color in objects. So, a blue fabric has blue pigment and will only appear blue if part of the light that strikes it contains a blue wavelength. Since white light has all the colors of the spectrum, all pigments look natural in it. If the light hitting the blue fabric only contained a red wavelength,

the fabric would look like an off color shade red (depending on the fabrics makeup of primary and secondary pigments). True red, being a primary color, contains none of the blue wavelength. Similarly, the fabric would appear green if only a primary green light was shone on it; warm blue if magenta was shone on it and cool blue if cyan was shone on it (magenta and cyan being secondary colors that contain blue). The shades of blue will appear different since we based our "natural" blue color on observance under white light; remove one part of the light spectrum and any pigment will look different. For most beginners, the wrong selection of color can become a great calamity. The scenery, costumes and makeup can appear completely foreign to the designers and directors because they have most likely been viewing it all under relatively white incandescent light or slightly green florescent light. However, you can use color to your advantage with practice. A play's dramatic turn from depressing to happy could be made even more dramatic if the lighting transforms the entire set from cool to warm. If the scenery was predominantly blue this could be done by changing the lighting from a cool blue-green light that suppresses the blue fabric color, to a blue or violet light allows (or enhances) the warm natural color of the fabric to be viewed.

LIGHTING APPLICATION

The basic lighting theory is applied using standard theatrical equipment. This equipment also dictates the physical layout of the three-fixture theory. What follows is a description of lighting fixtures, their layout and an overview of the equipment used to power and control the fixtures.

DETERMINING LIGHTING AREAS AND FIXTURE NEEDS

To accommodate our lighting design, the area to be lit must be broken down into smaller units called focus areas. It is easiest to create 8-foot to 10-foot squares. The overlap from our fixtures, which must be selected to produce a 14-foot circle, allows overlap for even illumination from square to square. If we had an area of 20 feet by 20 feet to light (producing 4 areas) using the basic design discussed before, we would need a minimum of 8 fixtures in front and 4 fixtures above or in back. This would provide a basic well-lit platform area for viewing from the front. If the platform is to be viewed from three sides, the amount of fixtures needs to be modified by adding either one or two front lights per area for a minimum of 12 fixtures and still 4 fixtures from behind.

The same lighting method is used to light special areas such as a single person or piano. In this case, the focus area may be smaller in order to cover only the specified object and may affect the fixture selected. These fixtures are normally referred to as "specials."

FIXTURES

The basic lighting theory is applied using standard theatrical lighting fixtures. Several types are available, so different capabilities and uses must be considered. To achieve proper illumination, the fixtures must produce approximately 100 foot candles (fc) of light on the object. The footcandles are reduced when color is added to the fixture, which depends on the transmission value of the gel. The darker the gel the less transmission. Most fixtures are designed to produce this basic level of light when the beam is 14 feet in diameter.

There are several fixtures that have specific uses and most can utilize several different wattage lamps. Once the fixture is selected for the proper distance, the lamp must be chosen for the proper footcandles. Below is a brief list of the most common fixtures and their uses.

Ellipsoidal Reflector Spotlights (Lekos, Ellipsoids, ERS, 6x9, 6x12, etc.)



*Altman
360Q*

*ETC Source
Four Jr. Zoom*

A spotlight that produces a beam of light that is well defined with a hard edged circular beam. They are normally used for front lighting since there is little "spill" light coming from the fixture (fixtures with a lot of spill would light up the audience). Also, these fixtures are equipped with shutters that are used to shape the beam of light. Squares, rectangles and other geometric shapes are formed with these shutters and the beam can be cut off of the edge of the

stage or wall eliminating additional “spill” light. These fixtures, equipped with a “template slot,” can shape the beam of light in different ways. Template slots allow the use of patterns (templates, gobos, cookies, etc.), that come in many designs ranging from simple breakups, which add texture to the light, to custom designs. All fixtures create a cone-shaped beam of light. When a fixed focal-length fixture is placed at different distances from an object, the diameter of the beam of light directed at the object changes (the further away the larger the beam). The focal length is a measurement of the lenses in a fixture and determines the size of beam it will produce. More expensive versions are available that vary the relationship between the lenses effectively altering their focal-length. With these the same beam size can be achieved at different distances. Once the location and distance from a focus area are determined, a fixture with the proper focal length must then be selected. The energy efficient Electronic Theatre Controls (ETC) Source Four Ellipsoidal, and newer Strand SL, have become the main workhorses in the industry. These fixtures provide crisp pattern projections, rotating shutter assemblies and low wattages with greater light output.



Colortran Mini Zoom

Scoops (Ellipsoidal Reflector Floodlights)

A fixture that produces a fixed open beam of light and are intended to light large areas such as backdrop curtains or cyclorama. Although the Scoops have the same shape reflectors as the Lekos, they have no lenses, and the quality of light is fairly soft. They have fallen out of use lately in favor of more efficient Broad Cyc fixtures that are now used to light backdrop curtains and cycloramas, and are relegated mostly to work lights.



Altman Focusing Scoop

Fresnel Fixtures

Spotlights that produce a very soft-edged beam of light that is not well defined.

These fixtures are often used for down or back lighting, although they can be used as front lights if the spill will not be a concern. They are less controllable than ellipsoidal in their focus because they have no shutters. Barndoors can eliminate some of the spill light, but the Fresnel Lens will always create spill and can never be completely shaped by the Barndoors. Fresnels are variable-focus fixtures; moving the lamp in relation to the lens can change the diameter of the beam, making them very flexible. Fresnels are the recommended choice for small systems and touring because they cost less than ellipsoidals and can be placed



Altman 65Q

at different distances to achieve the correct beam size.

PAR Cans

These fixtures are a more recent addition to theatrical lighting from the Rock & Roll business. Basically, they are housings that hold lamps similar to a car headlight. The lamps produce an intense oval-shaped beam that has a fixed beam spread. Because PAR lamps include the reflector, filament and lens in



Altman PAR 64

one unit, the lamps determine the width of the beam, not the fixtures. They are used for intense back lighting, but they can also be used for front lighting, when spill light and the shape of the beam is not an issue. The only way to create a wider beam from a fixed position is to replace the lamp. Lamps cost between \$30 and \$55, so this can be an expensive stock item. A new addition to the PAR fixtures are new energy efficient lensed units. ETC first introduced a theatrical version called the Source Four PAR. This unit uses the popular HPL lamp, a fixed reflector and interchangeable lenses. Now to create different size beams the reusable lens is changed (at a cost of approximately \$4). These lens come in the same beams spreads as the PAR lamps.

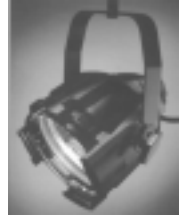

Source Four PAR

Borderlights (Striplights)

These units are continuous rows of lamps intended to light a large area, usually from overhead. They have also been used to light cyclorama curtains and are usually used in theaters where they can be concealed behind border curtains. This fixture typically has three or four alternating colors and can easily provide separate color washes from above. However, each color is controlled as one big area that can not be isolated into smaller areas. Because of cost and electrical efficiency, these fixtures are being replaced by Fresnels when used to light cyclorama curtains.



Altman R40

Broad Cycs

These fixtures produce a fixed open beam of light and are intended to light large areas such backdrop curtains and cycloramas. Somewhat similar to scoops, they have a specifically designed reflector to produce a more specifically shaped beam that also collects more light and puts it on the curtain with greater energy efficiency. They have no lens so the quality of light is somewhat soft.



L&E Broad Cyc

Followspots

Fixtures that are physically controlled by a person. They are mounted on a stand that allows the operator to follow a performer with a sharp-edged beam of light. The beam can be variable in size and the fixture generally includes six or more colors. They are available in many sizes and intensities to match any throw distance. Although they are generally used from the front, alternate positions from above can produce interesting highlights on the performer. This is the only sure method to follow a performer, especially while he or she is dancing or moving rapidly. New versions such as the SGM Newton incorporate electronically controlled iris and color. These can also be remotely controlled by any DMX control console. This allows preprogramming of the critical changes and allows the operator to focus on only moving the fixture to match the actors movement.



Altman Comet

Moving Lights

A recent addition to the entertainment lighting inventory, they can include a wide range of fixtures that are controlled on command. High End Systems, the most popular U.S. manufacturer, has set the standard for on-command moving lights with their Cyberlight, Intellabeam, Studio Color/Spot, Technobeam and Trackspot fixtures. Each unit contains dichroic filters so the colors can change on demand. The beam sizes are automatically variable and multiple patterns can be included in each unit. The fixtures can be used as front lighting, back lighting and special effects. New computer controls and belt packs can be included so that these fixtures can act as automatic followspots.



High End Cyberlight

Dimming and Distribution

Dimming varies the intensity of the lighting fixture. The distribution equipment is the set of electrical boxes that contain the individual receptacles into which the fixtures plug. For a new facility or portable installation, the quantity and locations of the receptacles and dimming can be designed once the quantity and position of the lighting fixtures are designed. In general, individual control of each fixture would be the most desirable. If this is not possible, group the control of the fixtures by angle and/or color. All front cools that come from the house right direction



*ETC
Sensor Rack*



Rosco/ET IPS Strip dimmer

could work together. Similarly, all same angle/color warms and then all same angle/color backs could work together. This is less flexible but allows you to dim the fixtures by color to change from day to night. Traditional dimming has included a centralized dimmer rack, such as the ETC Sensor, that feeds the distribution equipment. Distributed dimming systems using small dimmer packages that mount adjacent to the fixtures can reduce wiring costs and are excellent for portable systems. These systems include the NSI and Lightronics portable packs and the high quality Rosco/ET IPS Dimmer Strips.



NSI Dimmer Pack

Control

The control of the lighting can be just as critical as the selection of color and angles. An abrupt change of lighting at the end of a tender romantic scene can destroy the entire mood created by the actors. How the light changes from scene to



ETC Express

scene is an important part of the lighting design and can maintain or alter the continuity of the show. A good dimming system with a quality control console, preferably computerized for accurate playback, is important to any lighting design. The basic control console is termed a Preset Console, one or two rows of potentiometers are manually manipulated to set the lighting levels. Some of these units are enhanced with memory that records a full scene for playback from



*Lightronics Two Scene
Control Console*

each potentiometer. A Memory Console is a custom computer with both a keypad and potentiometers for playback of prerecorded cues and typically has a monitor for display of recorded information. There are some Memory Consoles, such as the Rosco Horizon, that are created by adding software and an output module to a standard personal computer. Any console purchased should produce DMX512 signal output to allow full operation of dimmers, moving lights and effects (fog machines, color changers, etc). The type of console is highly dependent on the number of these devices that may eventually be used in the facility. The console should be sized for the maximum number of control channels that will be required.



Rosco/ET Horizon

This concludes the basic description of the lighting theory and equipment necessary to fulfill the theory for a theatrical style lighting setup. Many factors are necessary to develop a complete setup of this equipment; however, this information will aid you in developing appropriate designs. Below is a short recap of the design process and equipment selection:

DESIGN PROCESS – RECAP

- 1) Design lighting layout for proper three-point illumination. Break platform into 8-foot to 10-foot focus areas. Include additional areas for specials.
- 2) From the layout of areas, select the proper positions for the lighting fixtures.
- 3) Select the lighting fixtures to produce the 12-foot to 14-foot beams based on the mounting distance to areas. The wattage of the lamps should also be selected for the proper foot candle level.
- 4) Connect lighting fixtures to the dimming system to allow for individual or angle/color groupings. Watch the wattage of your fixtures to be certain not to overload the dimmer.
- 5) Select the gel colors for appropriate mood of the production taking into consideration the scenery and costume colors.
- 6) Create lighting cues that enhance or direct the mood of each scene including the timing of lighting changes.

This article was originally written for a church publication but is applicable for any performance space.

Lighting noise in your Sanctuary.

Having a quiet Sanctuary is essential for moments of prayer, yet many facets of a lighting system can increase noise to a point of even disrupting a service.

There are several sources of lighting noise, the most basic being the filaments used in the lamps (light bulbs) of the lighting fixtures. Most filaments are quiet if given 100% of the voltage they require. If the fixtures are wired to a dimmer, the manipulated voltage from that dimmer can create an audible buzz in the lamp filaments. Dimmers switch AC current on and off to raise or lower the voltage supplied to a lamp, the lower the voltage the lower the intensity of the light. In actuality the voltage turns off for an instant on each half of the AC sine wave. The lamp appears to stay on because of the momentum of the heat built up in the filament. You may have noticed this at home when you turn-off the light switch the light does not go out instantaneously, but takes a few seconds to go out completely (cool off). The switching of the AC has the effect of slamming the filaments 120 times a second, which creates vibrations in the filaments. These vibrations are audible and are the cause of the hum that can be heard when lights are dimmed.

Many electronic dimmers utilize two Silicon Controlled Rectifiers (SCR's) to manipulate the voltage of one dimming circuit. These are the devices that turn on and off, or chop, the AC sine wave. Without filtering (slowing down the voltage), the slamming of the filaments would be so intense that it would reduce lamp life and present unbearable noise. The greatest amount of noise is generated when the lamp is dimmed approximately 35% to 70% of its output. Most churches will dim the congregation area not only to help draw focus to the platform, but also to set a calming mood. If the slide pots of your dimmer control are set to 5, you will have dimmed the light to its most noisy filament range. To reduce this filament noise lighting manufacturers add chokes to the dimming circuit. A choke is a doughnut shaped metal core with wires wound around it. This design creates a magnetic field, which slows the voltage as it passes through the wire wound around the core, lessening the slamming impact to the filaments. Filter chokes are measured in micro second rise time; the most basic choke is rated at 350 microseconds with 500 and 800 micro second rise time chokes also available. Generally, the higher the rise time of the choke, the less filament noise it will produce. Unfortunately to achieve higher rise time, the choke requires more wire to be wound around the core.



Choke

This increases the production costs; hence the dimmer will cost more. Inexpensive dimmer packs are less costly for a reason. They use lower quality components, including lower rise time chokes and ultimately may cost you more in repairs and noise problems. Purchasing a well-built dimmer is a worth while investment to reduce noise in the Sanctuary.

Aside from the filament hum, dimming induced noise in sound systems is always a concern. Through the operation of the dimmers RFI or Radio Frequency Interference can be produced. This interference is a radio signal that radiates from the dimmers and through the load wiring to the fixtures. Any sound related cable placed close to this wiring may pick up this RFI, which will disrupt the sound signals and thereby create a buzz in the sound system. This buzz will only be present when the dimmers are in operation and will increase and decrease in intensity especially within the 35% to 70% dimming range, the same range that causes the worst case filament noise. It is very easy to run sound extension cords to a new speaker or microphone location without taking into consideration the RFI created by the dimming system. Interference can also travel over the power systems in a building, particularly over the neutral wires. Sound equipment should have an isolated power feed to avoid the potential RFI produced by the dimmers.

Switchgear and distribution chatter is both a noise issue and a potential fire hazard. Switchgear can include disconnect switches, breakers panels, fuse boxes and transformers. Distribution is the wiring between the switchgear and the lighting fixtures. Modern dimming systems are larger in dimmer quantity, more heavily loaded with fixtures and more accurately fired than ever before. Electronic dimming can present many stresses on the electrical transformer that feeds the dimming system, which will make this switchgear chatter and potentially overheat the wiring and the transformer. In general terms, the SCR switching distorts the normally smooth AC waveform. This distortion is the worst in the dimming range of 35% to 70% and travels through all of the wiring involved in the system. A typical power feed to a dimmer rack would have three hot legs, one neutral and a ground wire (three-phase four wire + ground 120/208 volt service) all rated for 400 amps. A well-loaded dimmer rack could carry 300 amps of power per hot leg. If all of the dimmers are set for a 35% dimming range, it may be possible to measure 500+ amps being carried on the neutral wire. If your wiring is only sized for 400 amps, the neutral wire (which typically does not have a circuit breaker) could continuously draw the 500 amps, overheating the wire covering, wire connections and the transformer. At this point the main circuit breaker would not have tripped, because the draw on the hot legs is still below the 400-amp capacity. While conditions necessary to cause this are not typical, they are certainly possible under normal operations.

The chatter of the switchgear is an audible warning of a potentially critical problem. The chatter can also be very irritating, especially during quiet moments. This problem can then be magnified by the layout of the power feed and load wiring. A prime example of this is the design at Brownsville Assembly of God Church in Pensacola, Florida. The system was installed with the main switchgear directly behind the platform. The power feed runs through the floor, underneath the platform and first floor seating and then up a wall to the dimmer rack located in the balcony. The wiring to the fixtures runs from the dimmer rack and spreads throughout the ceiling. The basic shape of this wiring layout is a circle. Remember that dimmer chokes are circles with wires wrapped around them to produce a magnetic field. This installation created one large magnetic field. The noise in the Brownsville Sanctuary from the switchgear was extremely annoying to the Pastor and the Congregation. I believe the AC wave distortions produced by the SCR dimming affected this switchgear. The problem may then have been increased by

the magnetic field effect created by the wiring layout.

The fix for Brownsville was fortunately inexpensive. The dimming system they have in place had an option called Quiet Mode, similar to ENR mode, first marketed by Colortran, Inc. This dimming process alters the method of how the voltage is sent to the lamp filament. During the critical 35% to 70% dimming range, the SCR's in each circuit are fired differently to alter the AC wave distortions. This type of operation does not produce the same magnetic field or harmonic effects on the wiring. If Brownsville had not had this particular dimming system, the fix may have required replacing the dimmer rack, changing the run of feeder conduit or replacing the transformer, all very expensive alternatives.

There are several ways to minimize lighting related noise in Sanctuary's. Using dimmers with higher micro second rise time filter chokes will reduce audile noise and RFI, but not necessarily the switchgear chatter. Dimming systems are available that produce fewer harmonic distortions on the power feed by altering the method of SCR firing and utilizing devices other than SCR's. These systems produce less noise from filament hum, as well as reducing RFI and switchgear noise. Specific, and much more expensive, transformers are available to partially deal with the overloading of the neutral produced by the dimming harmonics. The layout of wiring can also influence these noise problems. Consulting with a Dimming Professional for the design of your lighting system will help insure that the proper equipment and wiring layout have been selected to avoid noise issues in your Sanctuary.

